

PORTABLE TUBING PUMP MANUAL

TABLE OF CONTENTS

SECTION	PAGE	SECTION	PAGE
1.0 SAFETY INSTRUCTIONS	2	5.0 TUBING REPLACEMENT	4
1.1 General Safety Considerations	2	6.0 CONTROL PANEL DESCRIPTION	5
1.2 Safety Operating Procedures	2	7.0 BATTERY REPLACEMENT	5
2.0 UNPACKING THE PUMP	2	8.0 TROUBLE SHOOTING	6
2.1 The Carton Should Contain	2	9.0 POLICIES AND PROCEDURES	6
3.0 PRINCIPLE OF OPERATION	3	9.1 Manufacturer's Product Warranty	6
3.1 Pump Head Features	3	9.2 Returns for Repair, Warranty or Credit	6
3.2 Portable Drive Unit Features	3		
4.0 PUMP HEAD COMPONENTS AND CLEANING	3		
4.1 Pump Head Cleaning Procedure	4		

PUMP SPECIFICATIONS

Electrical Input: 120 VAC, 60 Hz, 1.4 Amps, 1 Phase
Rechargeable Battery: 12 Volt, 7.2 Ah, Sealed Lead Acid
12 VDC Gear Motor: 1/10 HP, 400 RPMs, Variable Speed
Forward-Off-Reverse Switch: Hesitation Center Position
Percentage Dial for Flow Settings: 20% - 100%
Transfer Rate of Water at 0 PSI: 0.6 - 6.0 LPM
Maximum Pressure: 25 PSI
Size and (Weight): 9 1/2" x 10" x 10 1/2", (17 Pounds)

RolaTec Pump Co.

855 Village Center Drive, #321
North Oaks, MN 55127-3016

Ph. 651-334-3250 Fax 651-797-3732

www.rolatecpump.com, e-mail: sales@rolatecpump.com

MODEL MP-V400

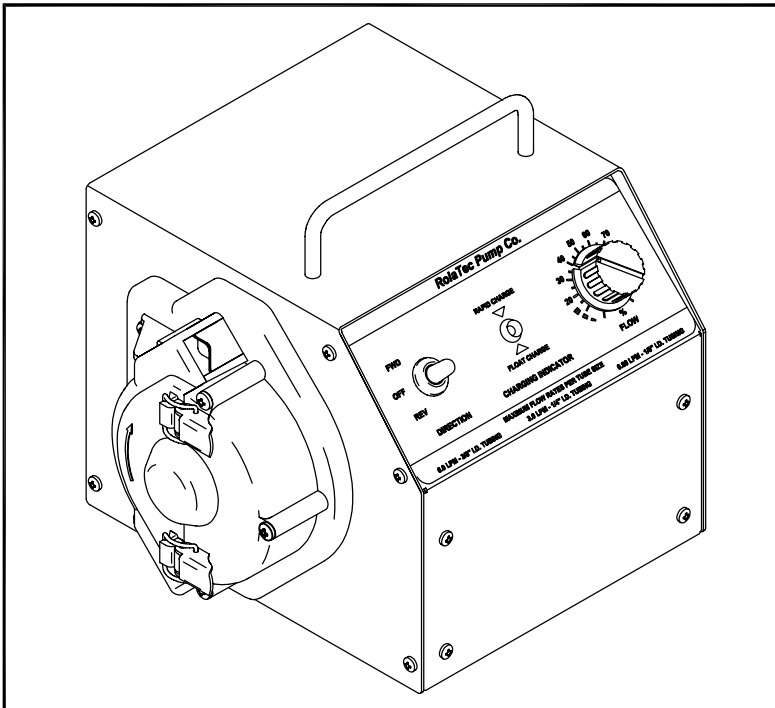

1.0 SAFETY INSTRUCTIONS

When using electronic tubing pumps, basic safety precautions should always be followed to reduce the risk of fire, electric shock and personal injury. More specifically, RolaTec pump model MP-V400 is not designed or intended for medical use in the treatment of patients and accordingly, has not been

submitted to or received FDA approval as a device for medical use. Also note that when pumping flammable or toxic fluids, the area should be properly ventilated. Failure to follow these instructions could result in serious injury or even death.

1.1 GENERAL SAFETY CONSIDERATIONS

Always wear protective clothing including gloves and safety goggles when working on or near the portable tubing pump.

Secure the tubing pump and any chemicals in an inaccessible manner away from children and pets.

Use only tubing that is specified for the pump and inspect it regularly for cracking or deterioration and replace as needed. Silicone tubing will last about 50 hours when pumping at maximum flow settings.

Make sure the voltage on the tubing pump matches the voltage at the outlet.

The pump is only splash proof, not weather proof or submersible.

Do not cut the plug or ground lug off of the electrical power cord.

1.2 SAFETY OPERATING PROCEDURES

Handle the pump with care. Dropping or heavy impact causes not only external damage to the pump, but also to electrical parts inside.

Never repair or perform maintenance to the pump while operating. Always disconnect electrical power.

When using the pump plugged in a continuous duty manner, do so in ambient temperature that doesn't exceed 100 Deg. F.

When using the pump in pressurized situations, make sure the pressure doesn't exceed the maximum pressure rating of the tube being used.

This pump is equipped with a power cord that has a grounding type three-prong plug. Only use a grounded receptacle when plugging the unit in. To disconnect, do not pull at the wire but grip the plug with our fingers and then pull it out. Do not use a receptacle in line with heavy electrical equipment. The surge voltage can cause failure of the electronic circuitry inside the pump.

Tubing pumps are designed to handle a variety of fluids which may contain chemicals that can cause irritation, illness or death if exposed to in an improper manner. Follow the manufacturer directions given with each type of chemical. Do not assume chemicals are the same because they look alike. We can not be responsible for the misuse of chemicals being fed by the pump. Always have the material safety data sheet (MSDS) available for any fluid being pumped.

2.0 UNPACKING THE PUMP

Check all equipment for completeness against the order and for any evidence of shipping damage. Shortages or damages should be reported immediately to the carrier and the seller of the equipment.

Hang on to the shipping carton and packing materials after purchase. The carton and packing materials are needed to ship the product back for warranty matters or to obtain credit for any returns.

2.1 THE CARTON SHOULD CONTAIN

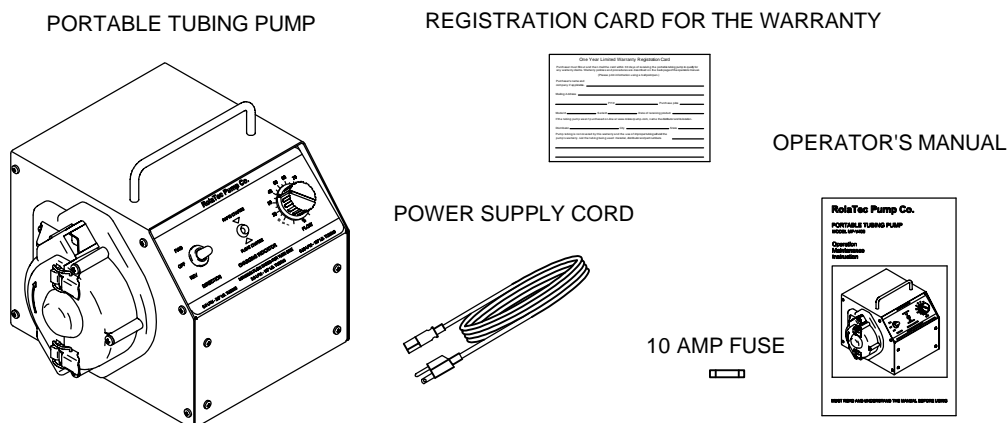

Note: The 10 Amp Fuse must be installed in back of the pump to operate.

3.0 PRINCIPLE OF OPERATION

By peristaltic means, fluid being pumped is confined to just the tubing. Typical applications include sampling, metering, dispensing, and any sterile type fluid transfer where the pump will not contaminate the fluid or the fluid will not contaminate the pump. The Portable Tubing Pump is comprised of three major components: peristaltic pump head, tubing and portable drive

unit. The pump head's rotor assembly and hood is what directly interacts with the tubing to produce the flow. The tubing is placed between the rotor and hood where it is squeezed. The rollers on the rotor move across the tubing to push the fluid. The tubing then recovers its shape, creates a vacuum, and draws in more fluid.

3.1 PUMP HEAD FEATURES

Self Priming: The pump head has a maximum lift of 25 feet, making the portable unit excellent for collecting samples in wells, sewers or lakes.

Rotor Assembly: Is removable for easy cleaning. The rollers have a dual bearing design for long life. The rotor is made of an engineering grade of thermal plastic material that will flex to compensate for slight variations of 1/8" wall tubing to increase tubing life, bearing life and battery life.

Spring-Loaded V-Clamps: Grip the outside of a tube to prevent it from traveling through during operation. This feature eliminates the need for fittings. Fittings create dead space where particles and bacteria can accumulate. The V-Clamps automatically secure 1/2" to 5/8" O.D. tubes.

Pump Head Materials: Celcon®, Stainless steel, Double shielded 52100 chrome steel ball bearings for the Removable Rotor; Glass-filled nylon for the Pump Base; Transparent blue polycarbonate for the Cover and Hood

3.2 PORTABLE DRIVE UNIT FEATURES

Portable: Weighs only 17 lbs. Can be used as a bench model when plugged into 120 VAC or used as a portable battery powered unit when unplugged.

12 VDC Gear Motor: 1/10 HP, 400 RPM, Permanent Magnet, Brush Type, Reversible.

Rechargeable 12V, 7.0 Ah Battery: The sealed lead acid, maintenance free battery powers the motor when not plugged in. Pumping water, a fully charged unit will move 6 LPM for 40 minutes when using 3/8" I.D. tubing.

Internal Power Supply / Quick Charger: Converts 120 VAC, 60 Hz to 12 VDC. Is only operational when the unit is plugged in. When the unit is switched On, the power supply runs the

motor. When the unit is switched Off and plugged in, the power supply charges the battery. It will take about 35 minutes to charge a low battery. The circuitry senses a fully charged battery and will limit excessive current.

Motor Speed Controller: Adjusts the flow rate from approximately 20% to 100% for a particular tube. Is repeatable to within 5% during intermittent use.

120 VAC Cooling Fan: Moves 20 cubic feet of air per minute inside the unit. It only operates when the unit is plugged in.

Aluminum Enclosure: Has a tough powder coated paint finish. Is designed to protect internal electronics from liquid splashes from above only.

4.0 PUMP HEAD COMPONENTS AND CLEANING

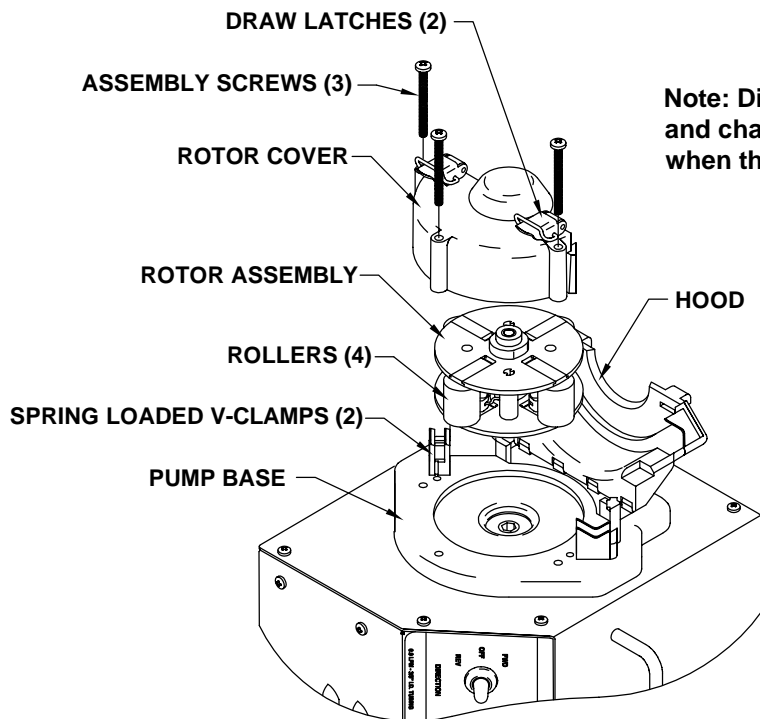

Note: Disassembling the pump head and changing the tubing is easier when the unit is placed on its side.

4.1 PUMP HEAD CLEANING PROCEDURE

Note: Clean the pump and surrounding area immediately after any chemical spills. The spring-loaded mechanisms are constructed to maintain their original spring tension and free movement as long as the unit is kept reasonably clean.

Remove the Rotor Assembly: Rotate the unit on its side to make the pump head more accessible. Follow the assembly drawing in "Section 4.0" to remove the rotor for cleaning.

Rotate the unit upright: Then use a damp cloth or sponge to wipe the enclosure and pump base clean.

Note: The unit is only splash resistant when upright.

Cleaning the Rotor Assembly: Never disassemble the rotor, just remove it. Rinse the removed rotor with warm water until it is clean. Dry immediately with compressed air if available. Assemble the pump head when completed.

5.0 TUBING REPLACEMENT

STEP 1

With the Hood open, position a Roller until centrally located as indicated by the large arrow. Place a tube over the Spring Loaded V-Clamps and around the centrally positioned roller at its middle height.

To increase tubing life, apply synthetic grease to area of tubing that comes in contact with the rollers. We suggest purchasing a 3-oz tube of food-grade synthetic grease with PTFE from McMaster-Carr Supply Co., Part #1378K31. Phone: 630-833-0300

Apply synthetic grease to tubing and inside corner of the hood.

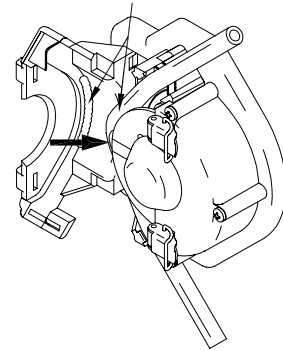

STEP 2

With the tube in place, drive the Hood down as indicated by the arrows. Then secure the Hood with both Draw Latches.

Note: If the hood is difficult to latch, the tubing may have moved partially over the top of a roller thus causing interference. Make sure the tubing is positioned to the side of the roller before closing the hood.

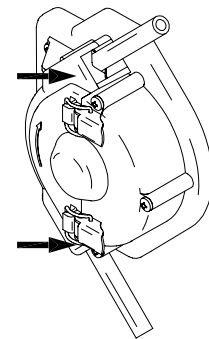

STEP 3

With the Hood now closed, pull the tube until it moves 1/8" to 1/4" through the pump as indicated by the large arrow. This is done to remove tubing slack within the pump head. The Spring Loaded V-Clamps will now hold the tubing in the proper alignment. Excessive tubing slack within the pump head will reduce tubing life, but over stretching the tube will reduce the flow rate.

The flexible tubing may slowly travel through the pump during operations above 10 psi head pressure if not secured with a 'Hose Clamp'. To avoid such movement, mount the Hose Clamp around the outside diameter of the tubing next to the inlet side of the pump head.

McMaster-Carr 'Snap-Grip Hose Clamp' Part Numbers

Ph: 630-833-0300, (20 per package)

5246K64 for 1/4" ID x 1/2" OD tubing

5246K66 for 3/8" ID x 5/8" OD tubing

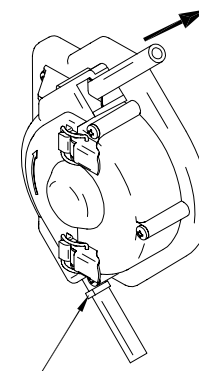

HOSE CLAMP

Note: Too small of a clamp will restrict flow.

6.0 CONTROL PANEL DESCRIPTION

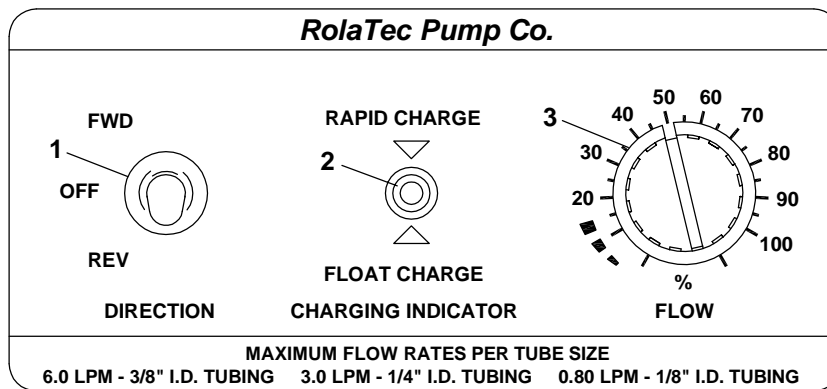

1) **Direction Switch:** Sets the direction of flow through the tubing. The arrow on the pump hood is direction of flow when switched to Forward.

This switch has a hesitation center that prevents operation of the lever through the center or Off position until pressure is momentarily relieved.

Note: When operating from a 115 VAC outlet, pause for at least 1 second in the Off position before reversing the direction of flow. The switch should be to the Off position before plugging the unit in.

2) **Dual Color LED:** Indicates whether the internal charger is in the rapid or float stage of charging the battery. The charger only delivers current to the battery when the unit is plugged in and switched to the Off position.

Rapid Charge (Red LED): In the first stage of charging a low battery, the charger will deliver a higher current to the battery until it has nearly reached capacity. This stage will take about 35 minutes.

Float Charge (Green LED): The circuitry senses that the battery has nearly reached capacity. The current is then lowered to complete and maintain a full charge in a gentle manner. For best results, charge the battery at room temperature within one day of planned use.

3) **Flow Adjustment Knob:** To obtain approximate flow rates, use the "Maximum Flow Rates Per Tube Size" information listed on the control panel along with the adjustment knob. For example, when using 3/8" I.D. tubing and 3.0 LPM of flow is required, align the knob's indicator notch to the 50% graduation, (50% of 6.0 LPM is 3.0 LPM). The flow rates listed at the bottom of the control panel are based upon pumping water at 70 Deg F. with a flow setting of 100%.

Note: Flow will decrease substantially when pump head pressure goes above 15 psi. Flow will also decrease if pumping viscous fluids. For precise flow needs, calibrate the settings for your particular operating conditions.

7.0 BATTERY REPLACEMENT

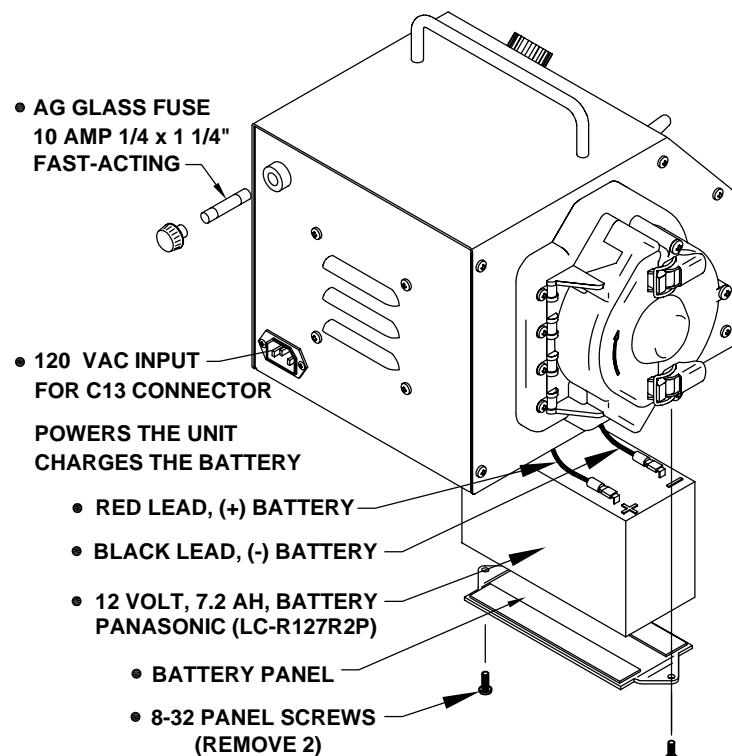

Once the battery doesn't hold a charge, it can be easily replaced by following these steps. The battery compartment is designed to accept a Panasonic 12 V, 7.2 Ah seal lead acid battery (LC-R127P2P). Check your local battery supplier for availability.

- 1) Unplug the unit and switch it to the off position.
- 2) Lay the unit on its side to remove the battery panel.
- 3) Place your hand over the opening and then rotate the unit upright. Shake the unit up and down by the handle just hard enough so the battery begins to slide out with your hand still below. Grab the battery and then pull it out.
- 4) Once again, lay the unit on its side to remove the leads from the battery and then attach them to the new battery. Red to Positive and Black to Negative.

Note: Disassembling the drive unit within two years after purchase voids all warranty claims. If any problems occur while still under warranty, contact RolaTec at 651-334-3250.

8.0 TROUBLESHOOTING

PROBLEM	PROBABLE CAUSE	REMEDY
FAILURE TO PUMP AT SPECIFIED FLOW RATES	<ol style="list-style-type: none"> 1. The tubing was not properly installed. 2. Using the wrong size tubing. 3. Pumping a viscous fluid or the flow is restricted on the outlet side of the tubing. 4. The tubing is wore out. 5. Operating an unplugged unit with a low battery charge. 6. Operating the pump with tubing that is too stiff or thin. 7. There is an electronic malfunction. 	<ol style="list-style-type: none"> 1. Refer to section 5.0, Tubing Replacement. 2. Measure the inside dia. of the tube being used then see 6.0, Control Panel Description, Item 3. 3. For precise flow requirements, calibrate the flow settings for your particular operating conditions. 4. Contact the seller for tubing replacement. 5. For charging, plug the unit in. Refer to section 6.0, Control Panel Description, Item 2. 6. Use specified tubing. Visit www.rolatecpump.com and click on the Tubing Selection link. 7. Contact RolaTec.
ROTOR WILL NOT ROTATE WHEN SWITCHED TO FORWARD OR REVERSE	<ol style="list-style-type: none"> 1. Attempting to operate an unplugged unit with a dead battery. 2. The tubing was not properly installed. 3. Attempting to operate the pump with tubing that is too stiff or thick. 4. There is an electronic malfunction. 	<ol style="list-style-type: none"> 1. If the battery doesn't take a charge, refer to section 7.0, Battery Replacement. 2. Refer to section 5.0, Tubing Replacement. 3. Use specified tubing. Visit www.rolatecpump.com and click on the Tubing Selection link. 4. Check the 10 amp fuse before contacting RolaTec.
TUBE LIFE IS VERY SHORT	<ol style="list-style-type: none"> 1. The tubing was not properly installed. 2. The chemical solution being pumped is not compatible with the tubing material. 	<ol style="list-style-type: none"> 1. Refer to section 5.0, Tubing Replacement. 2. Visit www.rolatecpump.com and click on the Tubing Compatibility link for proper material.

9.0 POLICIES AND PROCEDURES

If the pump was purchased from RolaTec Pump Co., then contact RolaTec directly for service matters, warranty work and returns. RolaTec reserves the right to update pricing and design without notice.

9.1 MANUFACTURER'S PRODUCT WARRANTY

The manufacturer warrants its product to be free of defects in material or workmanship. Liability under this policy extends for 2 years from the date of purchase. The manufacturer's liability is limited to repair or replacement of any device or part, which is returned, prepaid, to the factory and which is proven defective upon examination. In no event shall the manufacturer's liability exceed its selling price of such device.

The manufacturer disclaims all liability for damage to its products through improper maintenance, use or attempts to operate such products beyond their functional capacity, intentionally or

otherwise, or any unauthorized repair. Replaceable tubing is expendable and is not covered by any warranty either expressed or implied. The manufacturer is not responsible for consequential damages, injuries or expense incurred through use of its products. Contact RolaTec before attempting any questionable function.

The above warranty is in lieu of any other warranty, either expressed or implied. RolaTec makes no warranty of fitness or merchantability. No agent of ours is authorized to make any warranty other than the above.

9.2 RETURNS FOR REPAIR, WARRANTY OR CREDIT

Contact the distributor to obtain a Return Authorization (RA) number for any returns requiring repair, warranty work or if returning entire product for credit. The distributor may ask that the pump be shipped directly to RolaTec Pump Company. No returns for credit will be accepted beyond 30 days after the date of purchase. All items must be present with a copy of the invoice or receipt. Credits are based upon the acceptance of materials

as being new and unused by the inspection people of the manufacturer. The buyer will only be reimbursed a maximum of 90% of the purchase price due to restocking fees. All returns must be properly packaged, free of hazardous chemicals and have the freight prepaid. Type or print the issued RA number just below your return address. Have the following information ready before contacting the distributor:

- | | |
|----------------------------------|----------------------|
| 1. Billing and a ship-to address | 4. Reason for return |
| 2. Model and serial number | 5. Invoice number |
| 3. Contact name and phone number | |